

The Facet Fuel-Gard® VF-21SB/22SB, when configured as a coalescer separator, is an economical, compact housing designed to remove water and solids from aviation fuels.

Both interior and exterior surfaces of the carbon steel body are epoxy coated to protect against corrosion. This sturdy, single cartridge housing is easy to maintain and requires only 2" (51 mm) base clearance for cartridge change out.

STANDARD HOUSING DESIGN

- Carbon steel body
- Aluminum head
- Epoxy coated internally and externally
- 150 psi (10.5 kg/cm²) design pressure
- Swing bolt quick open closure
- Buna-N o-ring closure gasket
- Vent and drain connections w/brass petcocks provided
- 1-1/2" NPT inlet and outlet connections

VESSEL OPTIONS

VF-21SB	Housing only
VF-21SB-PG	Housing w/ Direct Reading Differential Pressure Gauge
VF-21SB-PGS	Housing w/ Direct Reading Differential Pressure Gauge & Sight Glass
VF-21SB-PGWP	Housing w/ Direct Reading Differential Pressure Gauge & 3/4" Coupling for Water Probe
VF-21SB-S	Housing w/ Sight Glass
VF-21SB-WP	Housing w/ 3/4" Coupling for Water Probe
VF-22SB	Housing Only
VF-22SB-PG	Housing w/ Direct Reading Differential Pressure Gauge
VF-22SB-PGS	Housing w/ Direct Reading Differential Pressure Gauge & Sight Glass
VF-22SB-PGWP	Housing w/ Direct Reading Differential Pressure Gauge & 3/4" Coupling for Water Probe
VF-22SB-S	Housing w/ Sight Glass
VF-22SB-WP	Housing w/ 3/4" Coupling for Water Probe
644160	Mounting Bracket
644964	Grounding Cable

Differential Pressure Gauge - The piston-type differential pressure gauge provides a simple visual warning. When 15 psi differential pressure is reached, the gauge indicator moves from green to red zone. This warning will prevent premature cartridge change-out.

Water Sight Glass - The water sight glass provides an easy means to detect water in the sump. The weighted ball, visible in the sight glass, will float only when water is present. The floating ball is an indication water should be drained from the housing to prevent both cartridge contamination and water traveling downstream from the housing.

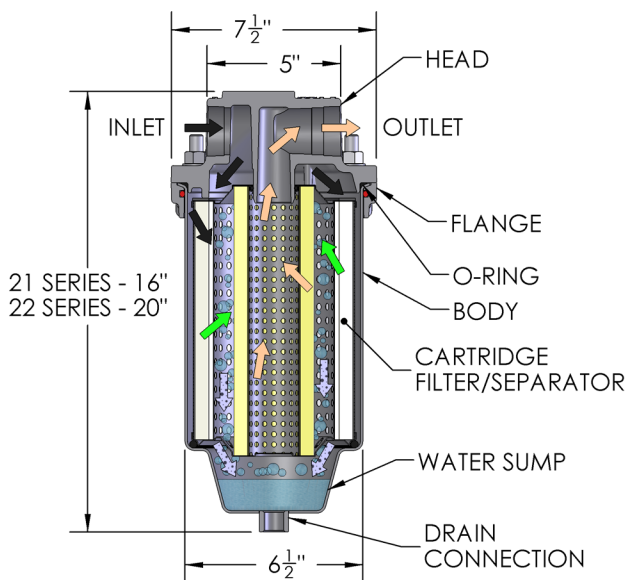
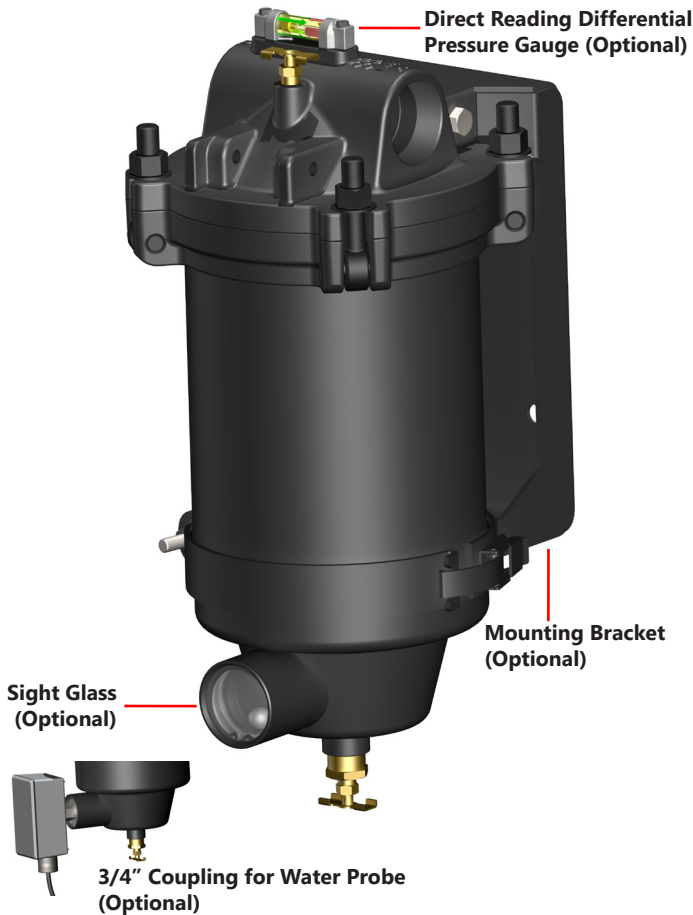

- ➔ CONTAMINATED PRODUCT
- ➔ SOLIDS FREE PRODUCT
- ➔ COALESCED LIQUID DROPLETS
- ➔ CLEAN, DRY PRODUCT

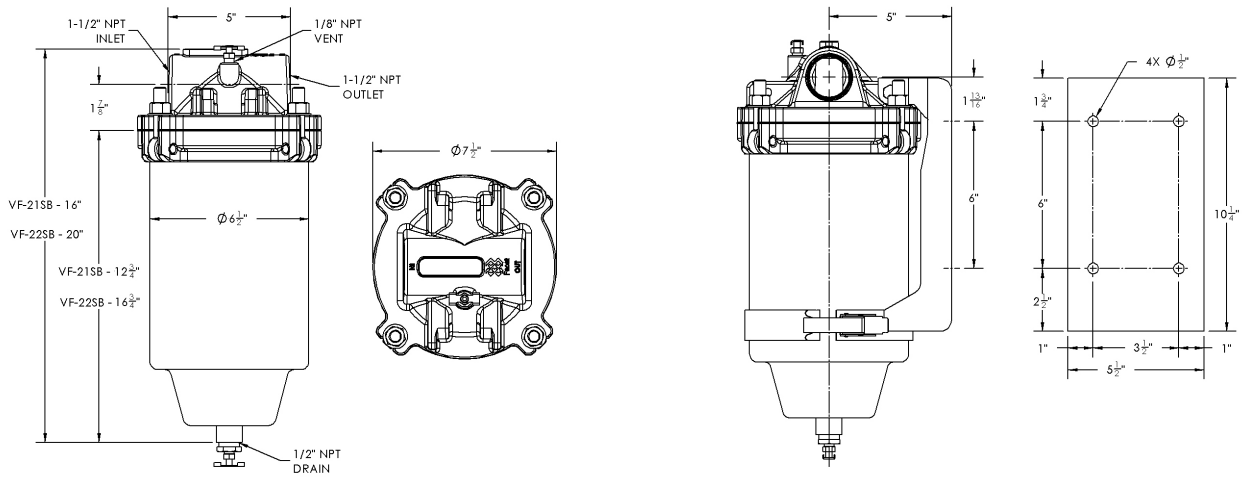

VF-21SB/22SB Coalescer Separator Cartridges

Facet VF-21SB/22SB Series coalescer separator cartridges provide long service life and high solids holding capacity with no unloading characteristics. These filter separator cartridges effectively remove water and solids from fuels.

STANDARD DESIGN FEATURES

- Recommended maximum operating temperature: 240°F (115°C)
- Maximum differential pressure: 75 psi (517 kPa)
- Fluid pH range: 5 to 9
- Flow Direction: Outside to In

MATERIALS

- Carbon steel structural components
- All metal components coated to protect against corrosion
- Standard gaskets are Buna-N—other materials available upon request



MODEL NUMBER	ELEMENTS	JET FUEL		JET FUEL (1)		AV-GAS	
		gpm	lpm	gpm	lpm	gpm	lpm
VF-21SB	CC-21-7	35	140	15	57	45	170
VF-22SB	CC-22-7	50	284	21.2	80	60	227

1) Tested to meet the effluent requirements of EI 1581, Fifth Edition, Category C & M, Type S-LW