

STANDARD HOUSING DESIGN

- Carbon steel body
- Aluminum head
- Epoxy coated internally and externally
- 150 psi (10.5 kg/cm²) design pressure
- Swing bolt quick open closure
- Buna-N o-ring closure gasket
- Vent and drain connections w/brass petcocks provided
- 1-1/2" NPT inlet and outlet connections

VESSEL OPTIONS

VF-21SB	Housing only
VF-21SB-PG	Housing w/Direct Reading Differential Pressure Gauge
VF-22SB	Housing Only
VF-22SB-PG	Housing w/ Direct Reading Differential Pressure Gauge
644160	Mounting Bracket

Differential Pressure Gauge- The piston-type differential pressure gauge provides a simple visual warning. When 15 psi differential pressure is reached, the gauge indicator moves from green to red zone. This warning will prevent premature cartridge change-out.

These housings installed with one Fuel-Gard® monitor cartridge, will continually check the entire flow of fuel, not just mere samples, for water or solids contamination. By performing three jobs, this small compact monitor assures clean, dry fuel. It absorbs free and emulsified water, removes ultra-fine solids, and shuts down system flow when hit with a localized slug of water.

Both interior and exterior surfaces of the carbon steel body are epoxy coated to protect against corrosion. This sturdy, single cartridge housing is easy to maintain and requires only 2" (51 mm) base clearance for cartridge change out.

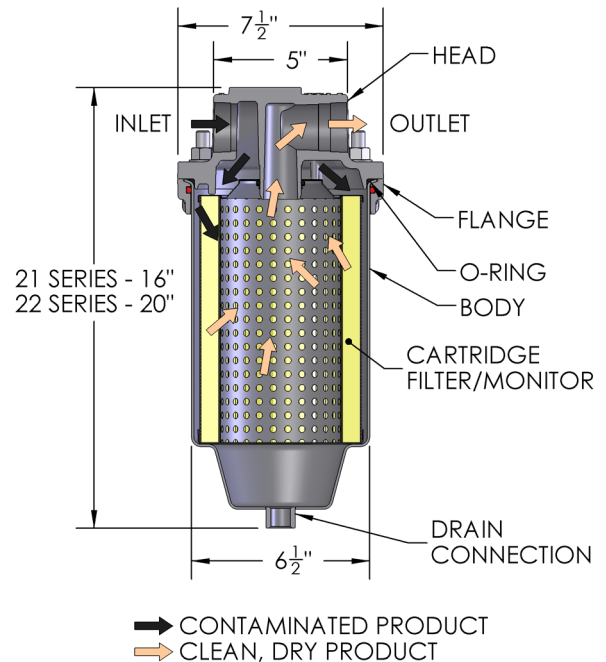

WARNING: MONITOR CARTRIDGES SHOULD NEVER BE USED WITH FUELS CONTAINING ANTHCING ADDITIVES SUCH AS FSII, PRIST AND DIGME. THIS INCLUDES PRE-MIXED AND MILITARY FUELS CONTAINING THESE ADDITIVES. THE USE OF MONITOR CARTRIDGES WITH FUELS CONTAINING ANTHCING ADDITIVES MAY RESULT IN (1) A FAILURE OF THE MONITOR CARTRIDGE AND/OR (2) MIGRATION OF FILTRATION MEDIA INTO THE FUEL STREAM, EITHER OF WHICH COULD POTENTIALLY CAUSE DAMAGE TO OR SUDDEN FAILURE OF THE CORRESPONDING ENGINE. THE SUPPLIER SHALL NOT BE LIABLE IN ANY RESPECT FOR ANY DAMAGE OR LOSS THAT ARISES FROM THE USE OF MONITOR CARTRIDGES WITH FUELS CONTAINING ANTHCING ADDITIVES. SUCH USE IS ENTIRELY AT THE USER'S RISK.

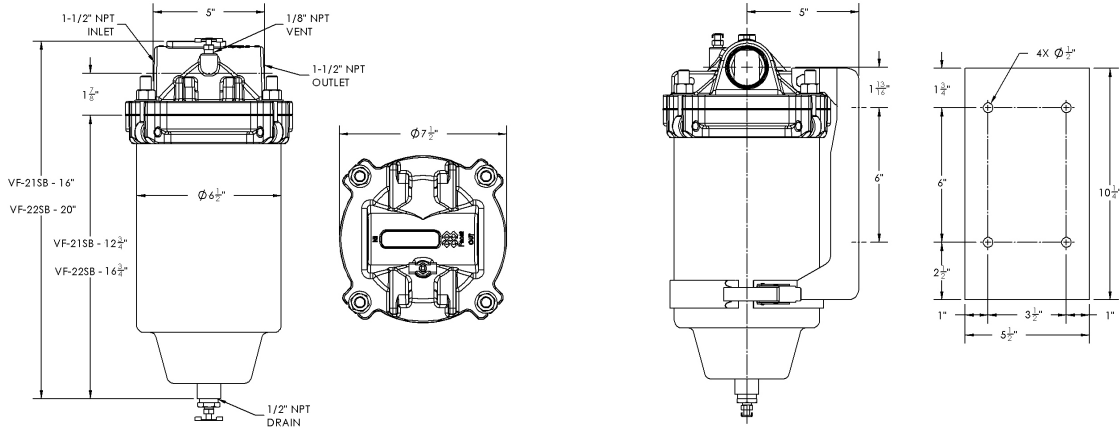

VF-21SB/22SB Monitor Cartridges

STANDARD HOUSING DESIGN

- Tested and qualified to meet latest edition of the EI Specifications and Qualification Procedures—Aviation Fuel Filter Monitors With Absorbent Type Elements
- Multi-layered media for increased solids holding, water removal and shutdown protection
- Less than 0.3 mg/liter of solids in effluent
- Less than 1 ppm of water in effluent
- Flow direction: Outside to in
- Not adversely affected by exposure to temperatures varying from -65°F to 160°F

MATERIALS

- Carbon steel structural components
- Heavy duty metal center tube and outer shell for extra structural strength
- All metal components coated to protect against corrosion
- Standard gaskets are Buna-N—other materials available on request

DATA

MODEL NUMBER	OUTSIDE DIAMETER		NOMINAL LENGTH		SHIPPING WEIGHT	
	in.	mm.	in.	mm.	lbs.	kgs.
21 SERIES						
FG-O-609-2	6	152	9	230	4	1.8
22 SERIES						
FG-O-612-2	6	152	12	300	6	2.7

FLOW RATES

MODEL NUMBER	JET FUEL				AV-GAS			
	INITIAL ΔP		FLOW		INITIAL ΔP		FLOW	
	psi	kPa	gpm	lpm	psi	kPa	gpm	lpm
21 SERIES								
FG-O-609-2	3.5	24.1	36	136	2.5	17.2	36	136
22 SERIES								
FG-O-612-2	5.5	37.9	48	182	3.5	24.1	60	227



The Facet Fuel-Gard® monitor cartridges meet the latest edition of the EI specification 1583—Aviation Fuel Filter Monitors with Absorbent Type Elements.

The cartridge is made up of layered and pleated, multi-media sections with inner support shells and an outer wrap. A special water absorbent media retains water and the pleats expand. As the maximum water-holding capacity is reached, a reduction in flow occurs, indicating the cartridge should be changed. Maximum recommended operating temperature is 160°F.